

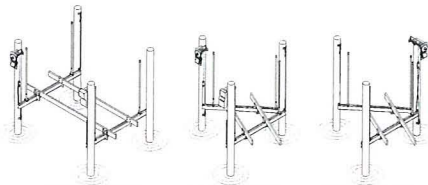

When It's Done Right...It's Golden!

INSTALLATION INSTRUCTIONS

GOLDEN 3T, 3 POST 2 MOTOR LIFT



GOLDEN 4T BOAT LIFT
2 MOTOR 4 POST

GOLDEN 3T BOAT LIFT
3 POST 2 MOTOR

GOLDEN 3-V BOAT LIFT
3 POST 1 MOTOR



PUB 990007.001

Golden Manufacturing Inc. 17611 East Street N. Ft. Myers, Florida 33917
Toll Free 888-909-5438 Phone 239-337-4141 Fax 239-337-4482 www.goldenboatlifts.com



When It's Done Right...It's Golden!

INSTALLATION INSTRUCTIONS GOLDEN 3T, 3 POST, 2 MOTOR LIFT

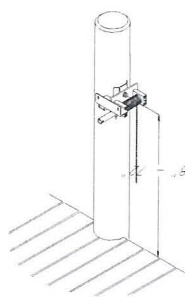

Step 1/ Drilling for the Drive Spool

Position the spool assembly on the inboard side of the piling at a distance of from 4' to 6' above the deck. Mount the spool mount plate to the piling using $\frac{5}{8}$ " \times 4" lag screws. Remove the lag screws and drill 2 - $\frac{3}{4}$ " \varnothing holes thru the piling. Use $\frac{3}{4}$ " stainless steel or galvanized bolts, nuts and washers. Drill the bottom hole when plate is level. Repeat procedure for opposite winder. Be sure stainless steel mounting bracket is between the piling and the spool plate.

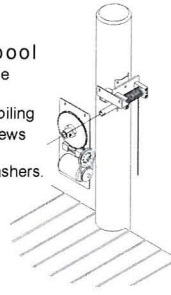

Step 3/ Drive Unit Assembly

Tap on the large pulley and align with the motor pulley. Tighten the Allen head set screws. Attach motor top holes to backing plate with short bolts provided. The longer bolts are for the bottom and are used for the attachment of the motor cover slide bracket. Place belt around both pulleys starting with the motor pulley.

IMPORTANT Be sure to check the rotation of the motors before operating the lift for the first time.

Bolt drive assembly to spool using pipe adaptor. Align holes and install $\frac{1}{2}$ " \varnothing bolt and tighten nut. Install the top $\frac{1}{2}$ " \times 1 $\frac{1}{2}$ " stainless steel bolt and motor cover pin and tighten with pins in "up" position. Attach bottom motor cover bracket with stainless steel wing nuts provided.



Step 2/ Mounting the inside cable tie-offs

Position the 24" bracket 3' above the lowest point necessary to get the boat on and off at low tide. Drill $\frac{3}{4}$ " \varnothing hole for the stainless steel cable bracket. Place the bracket on the piling and tighten. Drill the other hole and install bolt. Tighten all bolts. Repeat on other motor piling.

NOTE: Twelve (12) stainless steel 2" x 2" backing plates supplied are to be used between the piling and the washer and nut to prevent the washer and nut from being drawn into the piling.

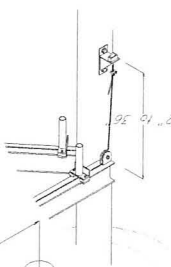

Step 4/ Mounting the outside cable tie-off

Position the cable tie-off on the piling at a distance of 12" to 36" above the cradle beam when the cradle beam is at the highest point. Mark the hole locations with a pencil. Drill a $\frac{3}{4}$ " \varnothing hole in the top of the bracket. Follow same procedure as Step 2.

Step 5/ Attach the bunk boards

Drill $\frac{7}{16}$ " \varnothing holes in the carpet covered bunk boards and attach to the angled bunk supports with bolts and nuts supplied. Tighten all nuts and bolts.

Grease all fittings on the lift and hoist. Place plastic covers over the drive units. Slide cover plate down and tighten the wing nuts. Place PVC pipes with caps over the galvanized pole.

You will also have to locate the center of the boat width and mark the cradle at that distance from the guide post base. This will be the distance to locate the center of the bunk board placement.

IMPORTANT Be sure when positioning the bunk boards that they are positioned so as not to come in contact with anything on the bottom of the boat. Then tighten down.

The lift is now ready for set up of the boat. **IMPORTANT** be sure the center of gravity of the boat is in the center of the lift before lifting. This is the position the boat should in at all times when lifting.

NOTE: Piling mount hardware is not included. Requires eight (8) $\frac{5}{8}$ " \times 4" lag screws and twelve (12) $\frac{3}{4}$ " \varnothing stainless steel or galvanized bolts, with nuts and washers to go thru piling and bracket.

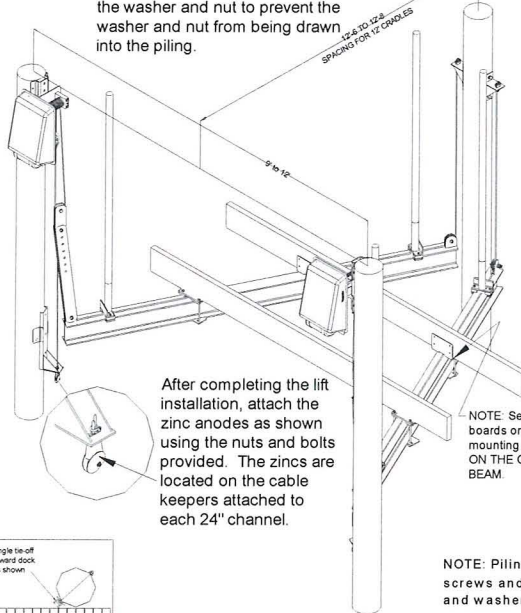

After completing the lift installation, attach the zinc anodes as shown using the nuts and bolts provided. The zincs are located on the cable keepers attached to each 24" channel.

NOTE: Seat the bunk boards on top of the mounting angle...NOT ON THE CRADLE BEAM.

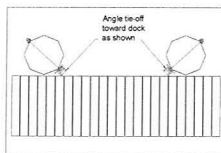

TIE OFF LOCATION DETAIL



Golden Manufacturing Inc. 17611 East Street N. Ft. Myers, Florida 33917
Toll Free 888-909-5438 Phone 239-337-4141 Fax 239-337-4482 www.goldenboatlifts.com